

BLENDING TECHNOLOGY AND TRADITION

Hoffco, Inc.

QUALITY WOOD MANUFACTURING

Instructions for installing
Reverse-A-Rack

Registered Trademark
Patent Pending

www.hoffcoinc.com

- 1 -

903-99-014
07/16/02

REVERSE-A-RACK

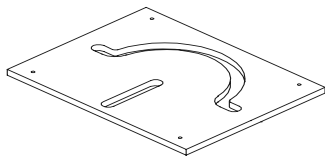
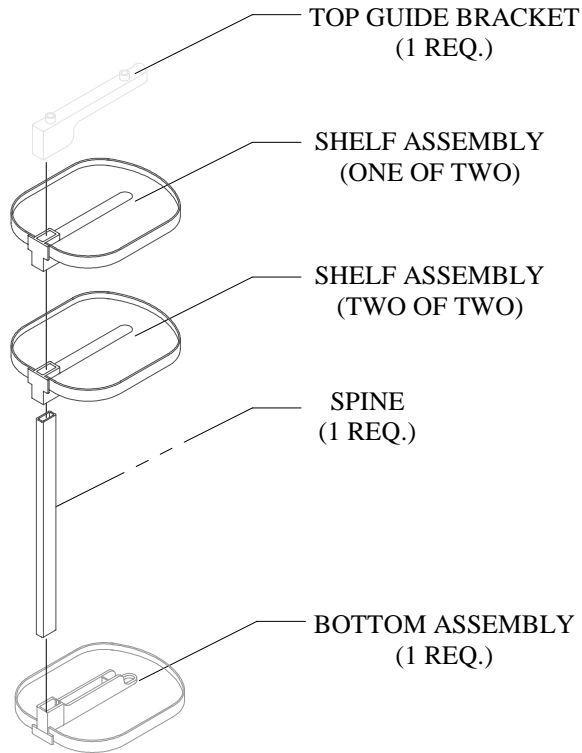

TOP GUIDE PLATE
(1 REQ.)

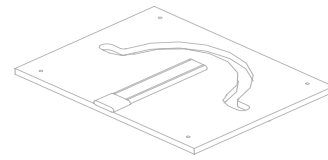

BOTTOM GUIDE PLATE (WITH SLIDE & CAP)
(1 REQ.)

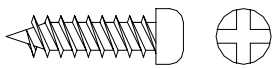

#8-1" PAN HEAD
(4 REQ.)

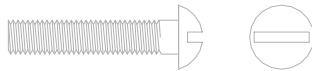

#10-24 X 1 1/4"



#10 .190-24 UNC NUT
(8 REQ.)



10 .190 WASHER
(8 REQ.)



1/8" "L"-KEY
(1 REQ.)

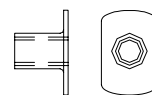

HORIZONTAL ADJUSTMENT NUT
WITH INTERNAL SET SCREW

Step 1. Installing the guide plates.

Factory Installed-

Center the top guide plate in the top of the cabinet. Drill four holes in the cabinet through the existing holes to accommodate the bolts. Repeat the process for the bottom guide plate in the bottom of the cabinet (see Fig. A).

Field Installed-

Same as factory if installer has access to outside top of the cabinet. If not, use #8x1" tapping pan head screws to fasten the top guide plate and use the bolts to attach the bottom guide plate.

Step 1A.

Step 1A. After installing the Top and Bottom Guide Plates, measure the distance between the two plates. After you have determined that dimension between the plates, you will need to subtract 2" from that dimension. That dimension will be the length the spine will need to be cut down to.

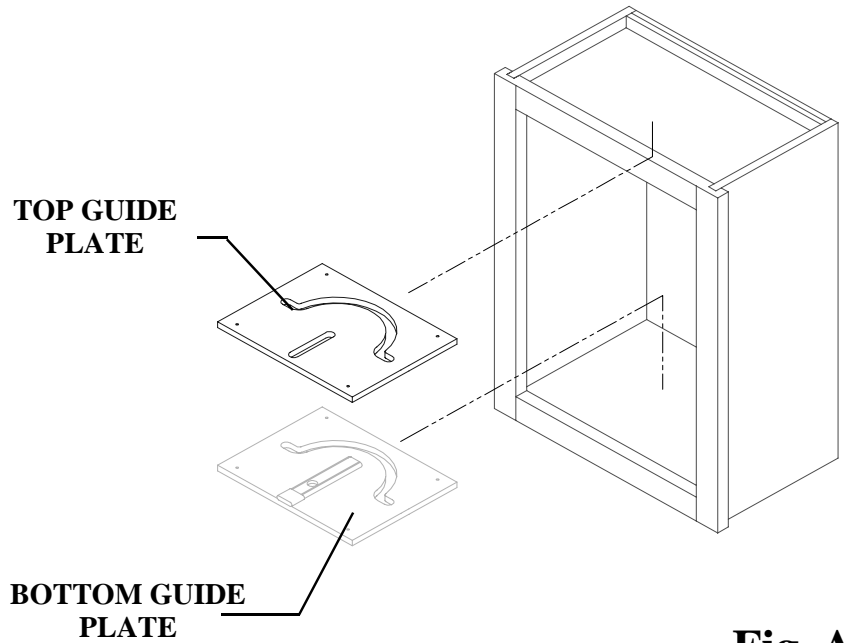
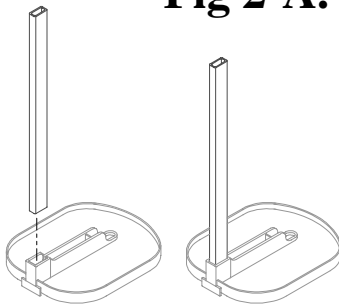

Fig. A

Fig 2-A.



BEFORE

AFTER

Insert the spine into the bracket on the bottom assembly as shown.

Fig 2-B.

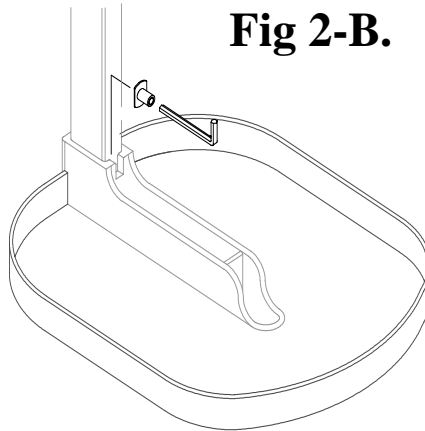

Insert the horizontal adjustment nut into the bottom assembly as shown in Fig. 5-B.

Fig 2-C.

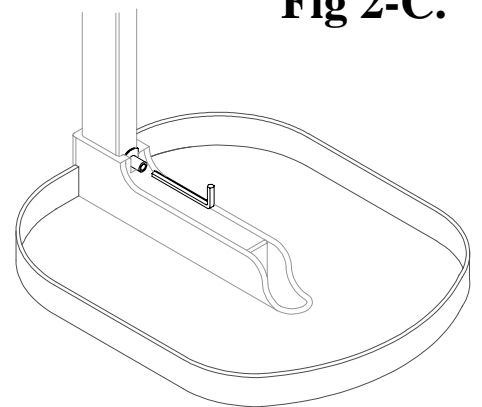

Using the allen wrench provided, turn the adjustment screw (being careful not to over tighten) in the bottom assembly until the unit is snug, so it no longer wiggles in the bottom assembly. (see Fig. 5-C).

Use "L" Key to tighten set screw into the spine.

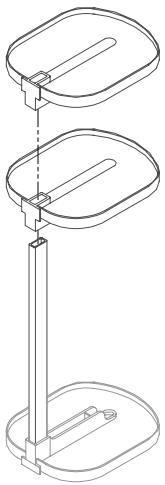
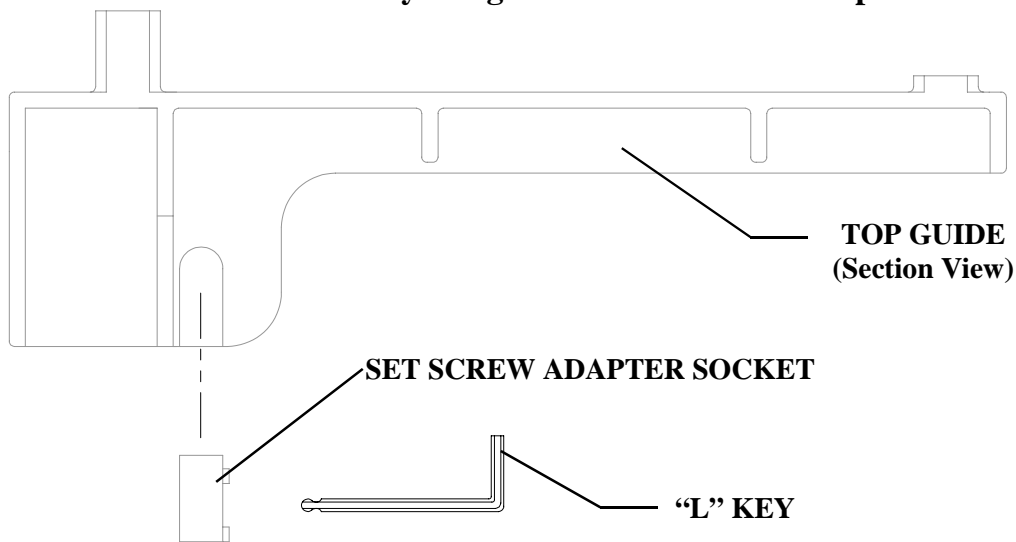
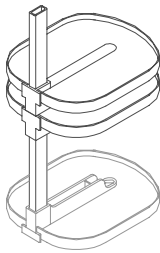

Fig 3.



BEFORE

AFTER

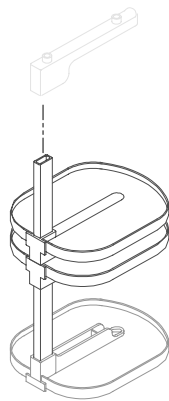
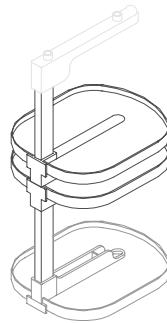

Fig 4.



BEFORE

AFTER

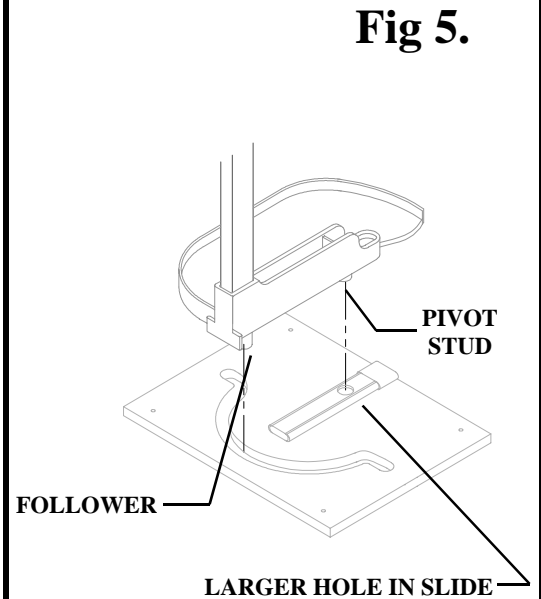

Fig 5.

Slide the two shelf assemblies on the spine, position at the midpoint, and lock using the "L" -Key to tighten the set screw (See Fig 3). Slide the top guide bracket onto the spine (See Fig 4). Carefully place the assembled unit into the cabinet. On the bottom assembly the follower pin moves within the curved channel, while the pivot stud fits into the larger hole on the slide (see Fig. 5). Slide the top guide up so that there is approximately 1/16" clearance between the top guide and the top guide plate. Secure using the "L" Key to tighten the set screw. The unit should cycle freely. Adjust the shelf assemblies to desired position.